

ATMOR

Hot Water **on Demand**

Installation and Operation Guide ThermoPro Thermostatic Series 18kW, 21kW, 24kW, 27kW



www.atmorusa.com



Table of Contents

Description	Page
Safety Guidelines	2
Technical Information.....	3
Plumbing.....	4-5
Mounting.....	5
Installation Procedure.....	6-8
Wiring	9
Starting the system.....	10
Operation Guide	11
Care and Maintenance	13
Troubleshooting.....	14

Important Safety Guidelines

1. Safety Guidelines

Read this manual thoroughly before attempting to install the instant water heater.

Failure to follow the safety instructions in this manual may cause damage to the unit, and could also result in property damage, personal injury, or loss of life.

Failure to comply with the safety, installation or operating instructions voids the product warranty.

The product manufacturer and the product distributor will not be liable for any damages or injury because of failure to comply with the installation and operating instructions specified in this manual or because of improper use.

Never attempt to install, disassemble, inspect or repair, disassemble or service the water heater without first shutting off all power to the unit by means of the circuit breaker on the main electrical panel.

The water heater must be installed by a licensed electrician and in compliance with all national, state, provincial and local electrical and building regulations.

Always contact your local authorized distributor for service.

2. Safety – Important Notes

- **Caution & attention:** for household and indoor use only & pour les menages et l'utilisation a l'interieur seulement. Do not immerse in water & ne pas immerger.
- For supply connection use 4 awg or larger wires suitable for at least 90°C (194°F).
- The heater must be installed by professional technician and according to the installation instructions.
- The heater must be grounded.
- The heater must be connected to a dedicated circuit breaker on the main electrical panel.
- The plumbing installation must be completed before the electrical installation.
- The plumbing installation requires metal pipes or reinforced hoses that can withstand pressure up to 8 bar.
- A pressure relief device (PRD) must be installed at the inlet of the water supply line.
- To ensure proper operation, the water supply flow rate must be at least 0.5 gpm.
- Do not install the heater where it may be subjected to direct sunlight, rain, splashing water, or freezing temperatures.
- This unit is intended for heating water only. Do not attempt to use the unit for heating any other kind of liquid.

Before connect the product to public power network, please consult your local power supply authority to ensure the power network meet above requirement.

SAVE THESE INSTRUCTIONS

Technical Information

Electrical Specifications

	ThermoPro 18 kw	ThermoPro 21 kw	ThermoPro 24 kw	ThermoPro 27 kw
Heating elements	3	3	3	3
Watts	18,000	21,000	24,000	27,000
Kilowatts	18 kW	21 kW	24 kW	27 kW
Voltage	240 V	240 V	240 V	240 V
Circuit Breaker Amperage	3 x 30 A	3 x 40 A	3 x 40 A	3 x 40 A
Breaker/Relay	3 x Single phase double-pole	3 x Single phase double-pole	3 x Single phase double-pole	3 x Single phase double-pole
Total Connection Load	75 A	87.5 A	100 A	112.5 A
Cable Size (minimum)	3 x 8 AWG	3 x 8 AWG	3 x 8 AWG	3 x 6 AWG

Plumbing Specifications

Minimum water flow to activate unit	0.5 gpm
Working pressure	0.5–10 bar (7–145 psi)
Tested pressure	20 bar (290 psi)
Water connections	3/4" NPT

Flow Rate

Temperature Rise Δt (°F)	Flow Rate (gpm)			
	ThermoPro 18 kw	ThermoPro 21 kw	ThermoPro 24 kw	ThermoPro 27 kw
81	1.6	1.8	2	2.2
74	1.7	1.9	2.2	2.5
63	2	2.2	2.5	2.8
54	2.4	2.7	3	3.3
45	2.85	3.2	3.6	4
36	3.6	4.1	4.5	4.9

Physical Dimensions

Height	Width	Depth	Weight
13 ³ / ₈ in. (340 mm)	17 ³ / ₈ in. (440 mm)	5 ¹ / ₄ in. (135 mm)	17 lbs (7.7 kg)

Plumbing

01

The plumbing installation must be completed before the electrical installation.

02

A pressure reduction device (PRD) must be installed on the heater's incoming water supply line prior to installing the unit. The maximum recommended operating water pressure is 8 bar.

03

Residential plumbing systems with unstable pressure or pressure above 5 bar require the application of a pressure stabilizer valve, set to 4–5 bar.

04

The plumbing installation requires pipes or reinforced flexible hoses that can withstand pressure up to 8 bar and that are rated for high temperature applications.

05

Copper water pipes are recommended for use within three feet of the unit's water inlet and outlet. Other types of piping can be used provided that are rated for high temperature applications.

06

If installing the heater on an upper floor or in an attic, be sure installation is in compliance with local code. Install a drip pan with drainage, or a leak detector and automatic shutoff valve, to prevent damage in case of a leak.

07

After plumbing installation is completed, carefully inspect all connections, unions, and the pressure relief device for leaks.

08

Before proceeding to electrical installation, run water through the unit for several minutes to flush out any air bubbles from the water line.

Mounting

01

The mounting surface must be solid and secure.

02

Use mounting screws that are at least 1 inch in length.

03

Make sure the unit is level prior to securing the mounting screws.

04

The unit must be installed in an upright position with the water inlet and outlet at the bottom.

05

Do not install the unit above electrical boxes or junctions.

06

The water heater must be installed in a manner that prevents contact with combustible materials. Keep combustible materials at least two feet away from the heater and hot water output pipe. The water heater and hot water outlet pipe must be securely out of the reach of children to prevent tampering with controls or contact with an extremely hot pipe.

07

If installing the heater on an upper floor or in an attic, be sure installation is in compliance with local code. Install a drip pan with drainage, or a leak detector and automatic shutoff valve, to prevent damage in case of a leak.

Assembly Instructions

01

Connect the Pressure Relief Device (PRD) to the unit (Fig1)

Note: IMPORTANT – do not discard this step. A PRD must be installed.

02

Remove the appliance covers (Figure 2).

03

Disconnect the cable from the PCB within the unit. (Figure 3)

04

Mount the unit on the wall with 4 screws at the marked points. (Figure 4)

Make sure the unit is horizontally level, with water inlets and outlets at the bottom. (Figure 5)

05

Connect the incoming water line to the heater inlet (on right side), and connect the outgoing water line to the heater outlet.

Use a hose that can withstand pressure up to 8 bar (Figure 5).

06

Run water through the unit for one minute, and make sure there are no leaks

07

Make sure power to the unit is shut off by means of the dedicated circuit breakers on the main electrical panel.

Run the power cable wires from the circuit breakers on the main electrical panel to the water heater.

Connect the power cable to the terminal block within the unit.

Make sure the correct breaker size and wire gauge have been used.

Make sure all wire connections are tight and secure.

Make sure the unit is connected to a ground in accordance with applicable codes. (Figure 6)

1

Washer

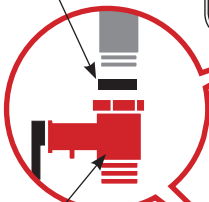

Pressure relief device

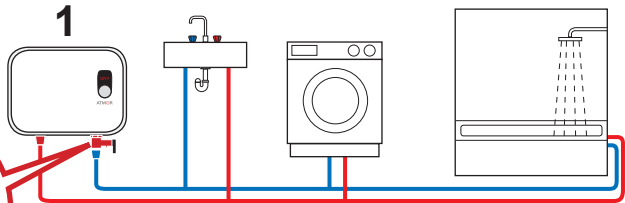

2

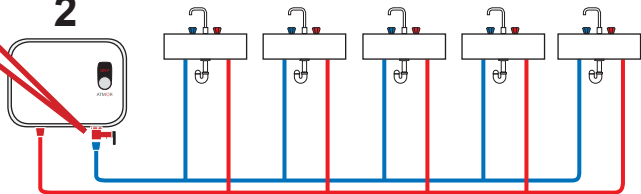

2



3

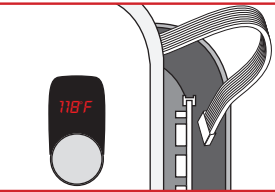

4

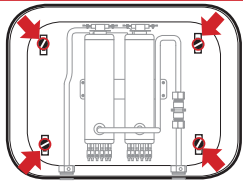

5

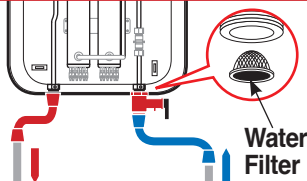

6

18kw-27kw

Note: Neutral (N) does not need to be connected.

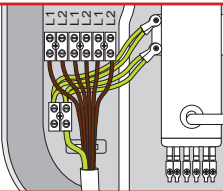

7

Assembly Instructions

08

Reconnect the cable to the PCB within the unit. (Figure 3)

09

Replace the front cover onto the unit and reattach it with 2 screws. (Figure 2)

10

Before turning on power to the water heater, open several hot water faucets and allow water to run through the unit for several minutes to purge any air from the heater and water lines.

This step must be performed before turning on power to the heater.

Failure to perform this step may result in permanent damage to the heating elements.

11

Restore power to the unit by means of the dedicated circuit breakers on the main electrical panel.

12

Do not install the heater where it may be subject to direct sunlight, and freezing temperatures.

13

Install the unit in a location that does not require significant modifications to plumbing and near the main electrical panel.

Electrical Diagram

2 Phase, 18kW, 21kW, 24kW, 27kW

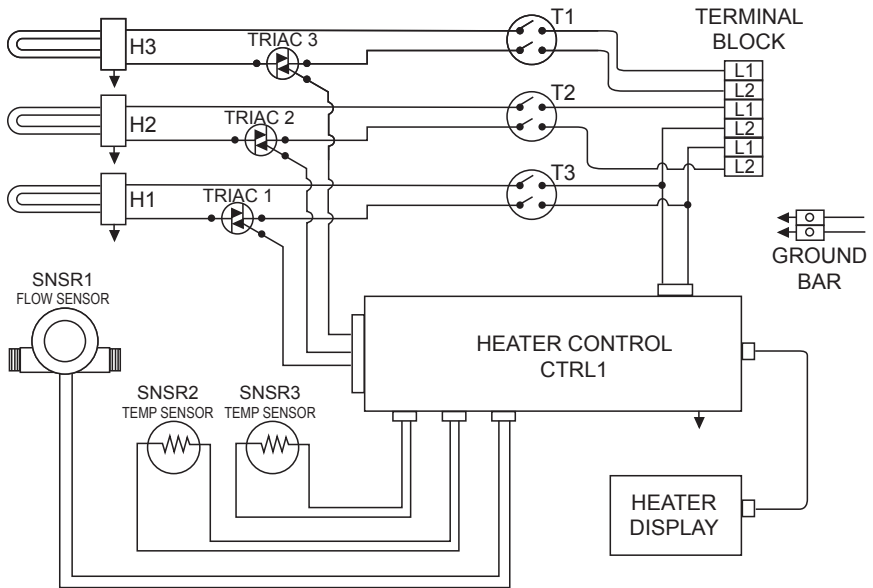

T1, T2, T3 = Thermostat
H1, H2, H3 = Heating Element
SNSR2 = Inlet Temperature Sensor
SNSR3 = Outlet Temperature Sensor

Starting the system for the first time

01

Turn the temperature knob clockwise to activate the heater to display outlet temperature.

02

With water running through the unit, turn the knob to adjust the temperature. The recommended temperature setting is 118°F (48°C).

03

The water heater is now ready for operation.

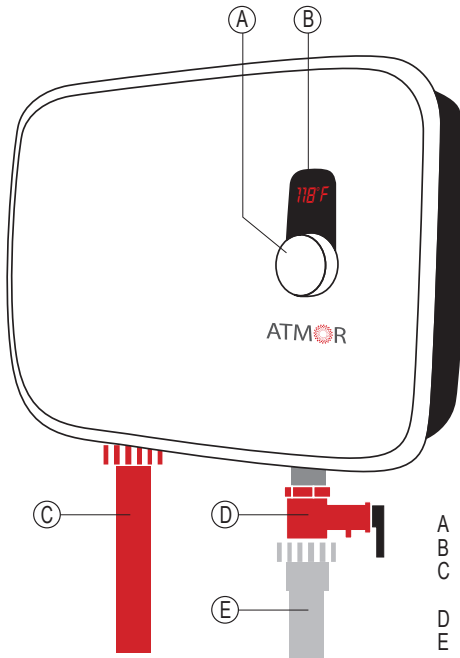

- A Temperature setting knob
- B Digital temperature display
- C Hot water outlet
(to be connected to the main hot water pipe)
- D Pressure relief device (PRD)
- E Cold water inlet

Operation Guide

Operating Instructions for the Home Owner

This electric water heater is designed to supply hot water for a house or apartment. Unlike a conventional tank storage water heater, this unit is a tankless water heater that does not store hot water. However, once you begin using the system, you will find it operates much like a conventional tank system.

Tankless systems deliver hot water instantaneously on demand. Since a tankless system does not waste energy continually heating water that is idly sitting and losing heat in a storage tank, it provides greater energy efficiency than a conventional system.

With your new system, as soon as you turn on a hot water faucet, the demand for hot water is detected, and high power heating elements are activated. Sensors continually monitor water flow rate and incoming and outgoing temperature, and transmit data to the system controller, which determines the exact amount of power required by heating elements to reach the set temperature.

It is important to keep in mind that all tankless water heaters are subject to a maximum flow rate. If this flow rate is exceeded, the heater will not be capable of fully heating water.

Also keep in mind that conventional tank heaters are set to high temperatures to prevent running out of hot water quickly, and thus a large amount of cold water needs to be mixed in to reach a comfortable level for washing and showering. Since this unit heats water on demand, it is designed to heat to a lower temperature. This means you only need to mix in a small amount of cold water, or none at all.

Your hot water supply may also be affected by the incoming water temperature. During winter, if incoming water temperature is very cold, you might not be able to run multiple hot water outlets at the same time. However, you can run showers back-to-back without having to wait for water to heat.

Setting the Output Water Temperature

To set the temperature, first turn on a hot water faucet and allow water to run through the heater.

The digital display lights up and shows the current temperature setting.

To increase or lower the temperature setting, press the UP or DOWN button.

Temperature can be set to a level from 90°F to 122°F (30°C to 50°C).

A comfortable temperature for bathing and showering is between 98°F and 105°F (37°C to 41°C).

The recommended temperature setting is 118°F (48°C), which will deliver hot water for all household needs at a maximum water flow rate. A higher temperature setting is not recommended, as it can cause serious scalding injuries to children and elderly persons. Higher temperatures also produce more scale buildup in water heating devices.

Operation Guide

Freezing Temperatures

If the ambient temperature falls below 32°F (0°C), protect the heater from potential damage. Shut off power to the unit by means of the dedicated circuit breaker on the main electrical panel. Open a faucet slightly to cause water to flow continuously through the device at a very low rate, without heating. Restore power to the unit when temperature conditions allow.

If the water inside the heater freezes, it can cause damage that is not covered by warranty. If you suspect water has frozen within the unit, do not turn it on until you are certain the frozen water has melted and there are no leaks in the unit. It is recommended to contact a qualified electrician or the manufacturer for service in this situation.

Leak Detected

If you detect a water leak from the water heater: Turn off the water supply at the shutoff valve on the unit's incoming water supply line, shut off power to the heater, and contact your local authorized distributor for service.

Care and Maintenance

The water heater has no required maintenance procedures, but periodic inspections and tests are recommended.

Remember that water heated to higher temperatures produces scale buildup much faster than at lower temperatures.

Clean the filter once a half year.

Electrical connections should be tested once a year by a qualified technician.

Plumbing connections on the water heater should be inspected at least once a year for any signs of damage or failure. If the water supply has a high level of mineralization (hard water), the water heater should be inspected and descaled more frequently.

As a result of maintenance or a water stoppage, air may be introduced into the plumbing system. Under such circumstances, follow the steps below to ensure the unit can safely resume operation.

Stopping and restarting the system due to servicing, water stoppage, or other interruptions of operation

Care and Maintenance

01 Press the power switch to the OFF position. Shut off all power to the unit at the circuit breaker on the main electrical panel.

02 Perform the maintenance or servicing tasks.

03 Open one or more hot water faucets and allow water to run through the unit for several minutes to purge any air from the heater and water lines. This step must be performed before turning on power to the heater. Failure to perform this step may cause permanent damage to the heating elements.

04 Reconnect power to the unit at the circuit breaker on the main electrical panel. Press the power switch to the ON position.

05 With water running through the unit, check and reset the temperature if necessary. The recommended temperature setting is 118°F (48°C).

Troubleshooting

Before calling for service, check the troubleshooting list of common issues.

If you are unable to resolve a problem, contact your local authorized distributor.

PROBLEM ISSUE	POSSIBLE CAUSE	SOLUTION
Water not hot enough.	The water flow rate exceeds the heating capacity of the heater.	Reduce the water flow rate at the faucet or slightly close the shutoff valve on the unit's incoming water supply line to reduce the water flow rate.
	Temperature setting is too low.	Increase the temperature setting on the unit.
	Water pressure is less than 0.5 bar (7 psi).	Make sure the shutoff valve is fully open and the water supply line is not blocked.
	Electrical malfunction.	Contact a qualified electrician or your local authorized distributor for service.
Water too hot.	The water flow rate through the heater is too slow.	Increase the flow rate at the water outlet.
	Temperature setting is too high.	Switch to a lower temperature setting.
Heater shuts off during use.	Power outage or faulty wiring.	Check the power supply. Check the circuit breaker. If problem persists, contact a qualified electrician or the manufacturer.
Water stops flowing.	Blockage in water pipes or hoses.	Make sure the main water line valve is fully open and there are no obstructions in the water supply line.
	No water supply.	
Water temperature varies from hot to cold during use.	Water pressure has dropped below minimum level.	Increase the flow rate from the water supply source.
No hot water even though the shutoff valve on the unit's incoming water supply line is fully open.	Power outage or faulty wiring.	Check the power supply. Check the circuit breaker.
	The flow rate needed to activate the heating element (0.5 gpm) has not been reached.	Increase the flow rate from the water supply source. Clean the filter screen on the unit's water inlet.

**If you have an issue and need further assistance,
please call: 1-888-783-6082**

LIMITED WARRANTY

The terms of this warranty is solely subject to the original owner and is at no time transferable. A transfer of ownership will result in an immediate termination of this warranty. This warranty is valid only if product is purchased from an authorized reseller.

Atmor warrants to the original owner that our instant water heaters will be free from defect in workmanship and material for a period of TWO YEARS from the date of purchase, and free from leakage for a period of SEVEN YEARS from the date of purchase. Should any part(s) prove to be defective during this period, Atmor will be responsible for replacement of the defective part(s) only. Atmor is not responsible for labor charges or any incidental or consequential expenses. Atmor's liability is limited to the cost of the product or \$1,000.00, whichever is less. Atmor is not an insurer and the original owner should purchase insurance to cover damage to property or belongings. The original owner agrees to waive their right to jury trial or to participate in a class action. In addition, the original owner agrees to waive subordination to the extent a loss is covered by insurance, so that their insurance company cannot proceed with action against Atmor for recovery of any claims. Furthermore, all claims must be arbitrated in the state of New Jersey.

Should the owner wish to return the water heater for repair, the owner must first secure a written authorization from Atmor. The owner shall be required to show proof of purchase date and to pay all transportation costs to return the defective part(s) or water heater for repair or replacement. Warranty is void if: (i) water heater has been installed or used improperly; (ii) design has been altered in any way; (iii) water heater has been installed and/or serviced by someone other than a licensed electrician ; (iv) or if the water heater has been installed or used in contradiction to installation instructions, applicable laws and/or ordinances.

A full and complete version of this warranty is available on the online, www.atmorusa.com, or upon request from an Atmor representative

Distributed by:

PARAGON GROUP USA LLC

Englewood, NJ 07631

USA

Phone: 1-888-783-6082

Email: info@paragongroupusa.com

Web: www.atmorusa.com



Call us first and let our service team help!

DO NOT RETURN TO STORE

Have questions about your unit or need service?

Please call:
1-888-783-6082

or email:
info@paragongroupusa.com

Our staff is ready to provide you with assistance.

Monday – Friday, 9AM - 5PM EST